



LEE C. MOORE[®]
A Woolslayer Company

EzTurn[™] BOP CRADLE

Rotating a BOP could never be easier.

The EzTurn[™] BOP Cradle from Lee C. Moore facilitates single-handed rotation of an entire blowout preventer stack. Wellhead alignment has never been easier.

Another innovative, patent-pending design from Lee C. Moore, a Woolslayer Company engineers. Simple, efficient and safe. Goodbye tugger lines!



Visit us online at lcm-wci.com or speak with an expert: +1.800.864.8794 | +1.918.523.9191
Onshore | Offshore | Masts | Derricks | Custom Drilling Equipment | Service

EzTurn™ BOP CRADLE



Features and benefits:

- Full 360° rotation
- Easy to install gate design
- Integral roller assemblies contact either underneath side of BOP annular or customer furnished 42 in. diameter (or greater) double studded adapter
- Various models fit all API standard flange sizes
- Lift point spacing built to customer specification.
- Hook-type primary lifting eyes unless specified otherwise
- Interfaces with various BOP stack configurations and annular
- Four Shoulder Type Machinery Lifting Eye Bolts accommodate secondary BOP hoisting or stabilizing lines
- Two mounting positions for BOP transport skid
- Two primary lifting eyes

Dimensions/Schematic

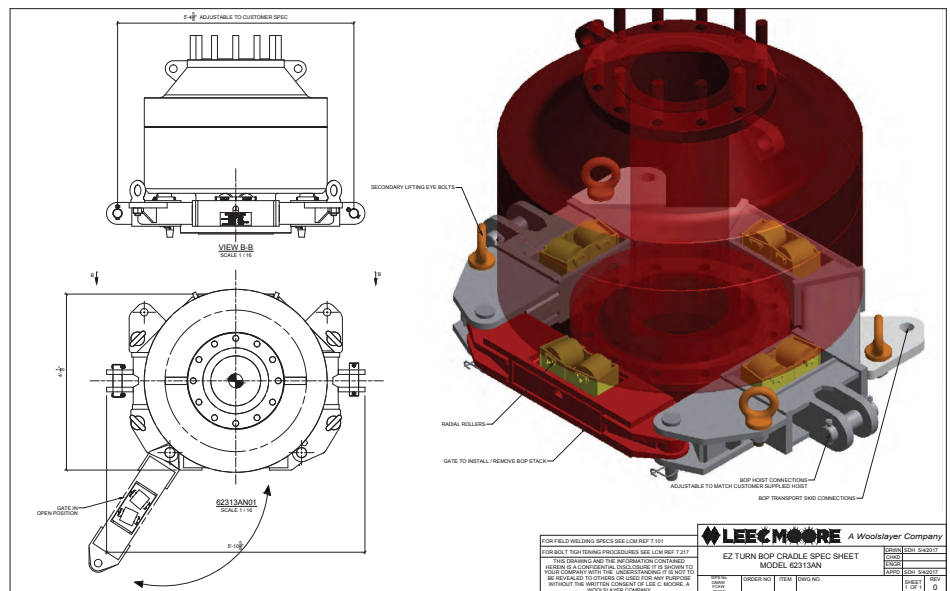

Contact Information:

TULSA OFFICE
5416 South Yale Avenue,
Suite 500
Tulsa, Oklahoma 74135 USA
t: +1-918-523-9191
t: +1-800-864-8794
f: +1-918-523-0854
e: sales@lcm-wci.com

HOUSTON OFFICE
9601 Katy Freeway
Houston, Texas 77024 USA
t: +1-832-925-7150
t: +1-832-925-7151

Specifications

1% (or less) Friction Coefficient for Rotating

20 ton - 60 ton Capacities

Drop-in Adapters to Accommodate Various Flange Sizes

Depth = 9"

Weight = 1,700 lbs